

Gallo Technologies

Model: 2DR / 4DR For GTS-3 and GTS-3RS

POWER DOOR LOCK ACTUATOR INSTALLATION MANUAL

2 DOOR AND 4 DOOR MODELS

INSTALLATION OF ACTUATORS

1. Carefully remove the door panels.
2. Align the actuator in the correct direction as shown in Fig 1-a, Fig 1-b, and Fig 2. Make sure the actuator does not obstruct any moving part within the door (window and associated mechanism). Move the window up and down to ensure it will not interfere with the actuator. Make sure the actuator rod moves parallel with the vehicle's lock rod.
3. Select an existing hole/s or drill two holes (Dia. 3/16") in the internal side of the door, then secure the actuator using supplied sheet metal screws.
4. Insert the vehicle lock rod and actuator rod into the supplied connector block as shown in Fig. 3 & Fig. 4. After ensuring there is adequate allowance for the movement of the connector block assembly, tighten the set screws.
5. Make sure the actuator's movement is parallel with the vehicle's lock rod, as shown in Fig 2. otherwise the actuator may not function properly or become permanently damaged.
6. For each front door (5-wire) actuator, make sure you have adjusted the stroke of the actuator and vehicle lock rod to the middle point of its full stroke before tightening the set screws in the connecting block which connects the steel rod and vehicle's lock rod. See Fig 4.
7. For the rear (2-wire) door actuators, make sure you have adjusted the stroke of each actuator to max. or min. stroke position, and push it in or pull it out respectively about 1/16" before tightening the set screws in the connecting block as shown in Fig 4. Then push and pull the door lock lever/knob to assure that the mechanism is working well. If not then readjust.
8. To test the actuator simply apply GROUND to the BLUE wire and (+) 12 volt to the GREEN wire. The actuator should travel in one direction, then reverse the connections and the actuator will move in the opposite direction.

INSTALLATION OF WIRE HARNESS

1. Mount the Power Lock Controller in a convenient location under the dash. DO NOT mount the controller in the door. It must be mounted in a dry location.
2. Make sure you have installed all the actuators and the wire harness before you connect the red and black wires to the battery +12v and ground.
3. When connecting the front door (5-wire) actuators and the wire harness together, make sure to connect the same color wires together. See Fig 5.
4. When connecting the rear door (2-wire) actuator and the wire harness together, make sure to connect the same color wires together.
 - Exchange the blue and green wires (actuator blue wire to wire harness green), if the lock/unlock direction of the rear door actuators are not synchronized with the front door actuators. The rear door actuators sometime need to function in the opposite direction because of mechanical mounting considerations.

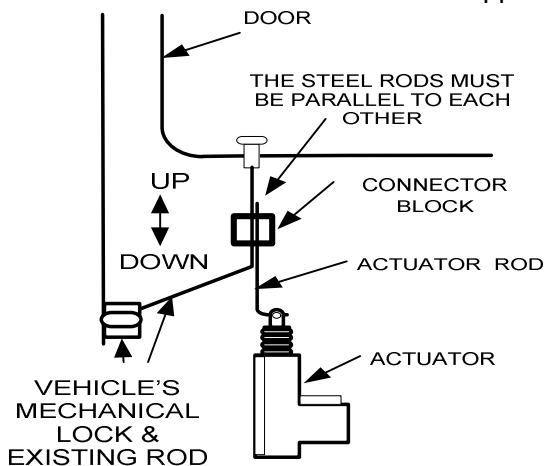

Fig 1 a. Vertical Mount Actuator

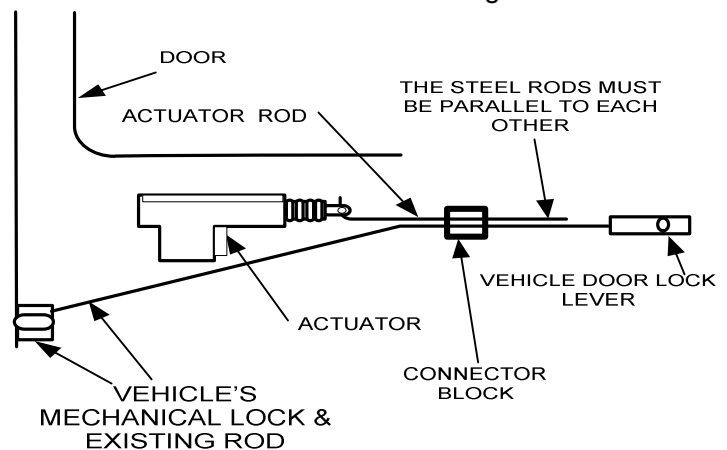

Fig 1 b. Horizontal Mount Actuator

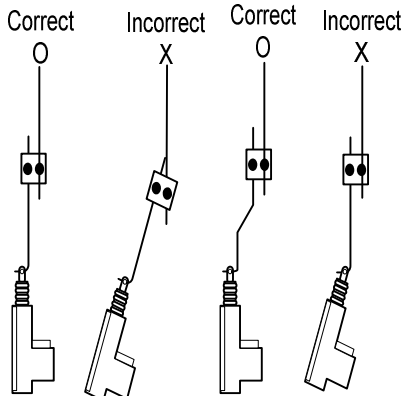

Fig. 2 ROD ASSEMBLY

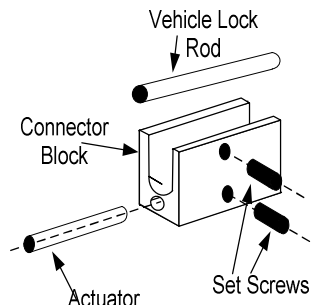

Fig. 3. Rod and Connector Block Assembly

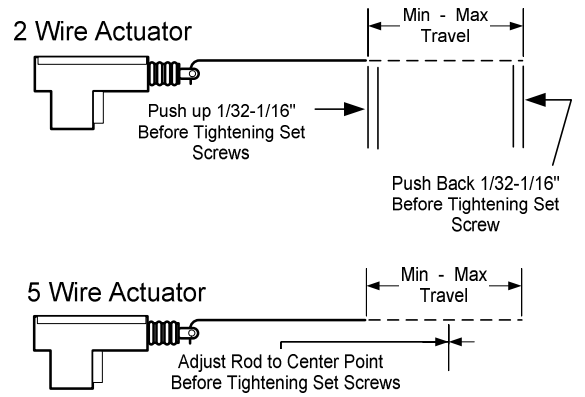

Fig. 4 STROKE ADJUSTMENT

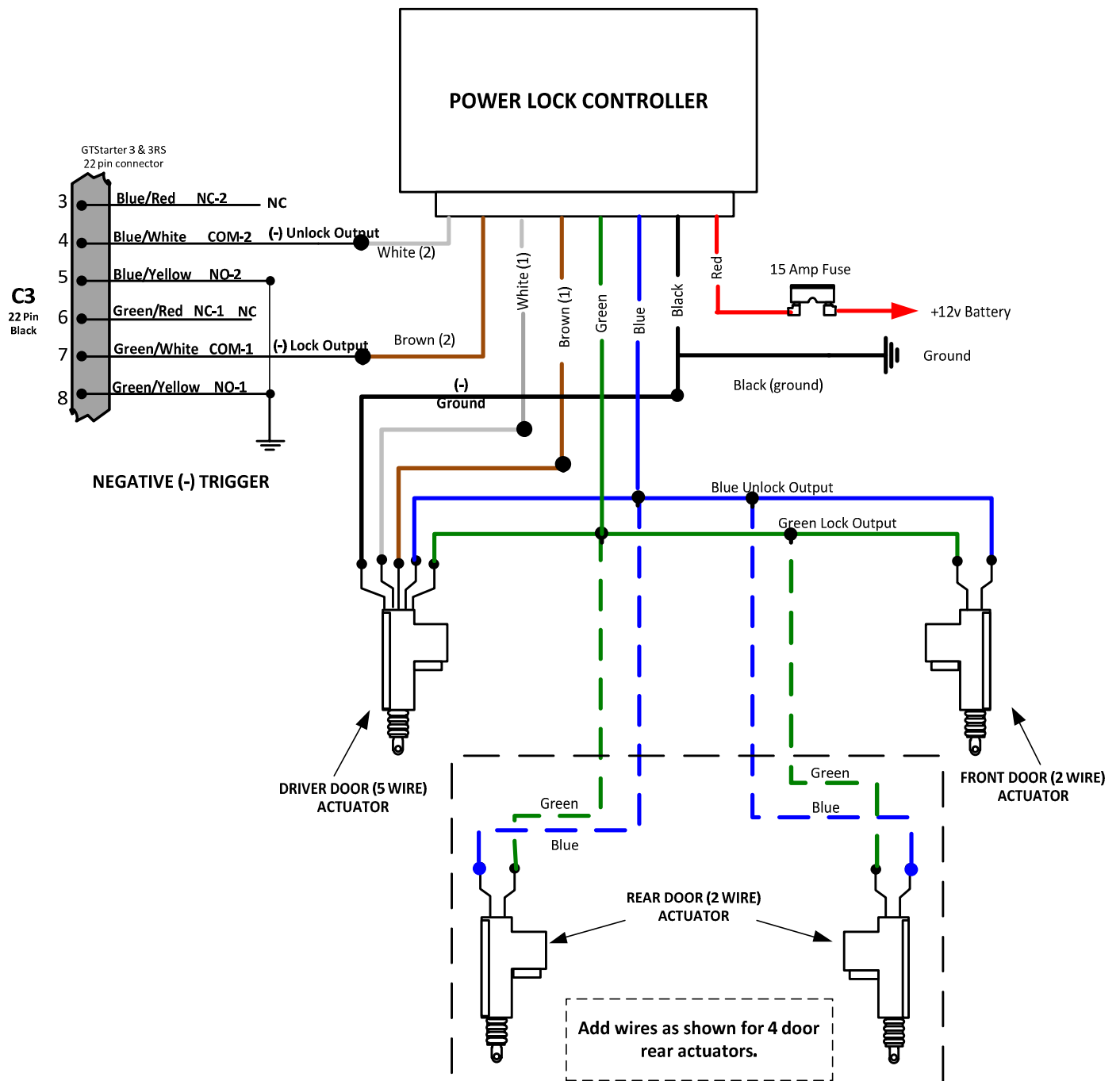

Fig. 5 WIRING DIAGRAM

TROUBLESHOOTING

ACTUATORS DO NOT WORK:

- a.) Check +12v and ground connections or the fuse.
- b.) Check the connection of the control unit with the wiring harness. All wires must be connected to the same color wires of the control module, wire harness and actuators.
- c.) Check to see if the control module is working. Ground the WHITE (1) then BROWN (1) wire of the harness. This will make the actuator contract or extend. (You might hear a click sound from the control module when you ground the WHITE (1) then BROWN (1) wires). If the actuators work after grounding the WHITE (1) then BROWN (1) then the problem is in the connection to the GTStarter 1 C2 / GTStarter 2 C3: wire harness.
- d.) If the actuators are not working after testing a), b) and c) above:
 - a. Check the mechanical assembly. Are any parts loose?
 - b. Check and correct the actuator movement and stroke. See Fig 1, 2 & 4.
 - c. Check the actuator by applying +12v to the BLUE, then GREEN wire. It should move up then down. **CAUTION:** disconnect the connector from the control module before doing this test).

LOCK GOES UP AND DOWN AUTOMATICALLY:

- a.) Disconnect the +12v power first.
- b.) Make sure the WHITE, BROWN, BLUE & GREEN wires of the actuator, wire harness and control module are connected with the same color wires. See Fig 5.

INSTALLATION NOTES